



RF Power Amplifier & Programmable Synthesizer

Including: Basic Deflector Alignment

Instruction Manual RFA1170-4 + iMS4-L

Models -

RFA1170-4+iMS4-L : 50-90MHz, > 240W total RF output

**DO NOT OPERATE
the RFA1170-4 types
or
LS700 type AO DEVICES
WITHOUT LIQUID COOLING**

* (Always refer to the AO test data sheet)

ISOMET CORP, 5263 Port Royal Rd, Springfield, VA 22151, USA.
Tel: (703) 321 8301, Fax: (703) 321 8546, e-mail: isomet@isomet.com
www.ISOMET.com
ISOMET (UK) Ltd, 18 Llantarnam Park, Cwmbran, Torfaen, NP44 3AX, UK.
Tel: +44 1633-872721, Fax: +44 1633 874678, e-mail: isomet@isomet.co.uk



1. GENERAL

The Model RFA1170-4 is a class AB amplifier designed to drive the LS700- series of Isomet high power Germanium acousto-optic deflectors with up to 300Watts across a 40MHz bandwidth. When fitted with the iMS4-L synthesizer and controller cards, the RFA1170-4 power amplifier exhibits programmable phase shift and amplitude compensation capability across the four RF output channels.

This model is optimized for very fast rise and fall times and may be operated CW.
(Always refer to the AO device data sheet).

The RFA1170-4 + iMS4-L combo includes a number of features to aid monitoring and control:

- Temperature monitoring and thermal Interlock for the Amplifier and associated AO deflector
- “-Enable” control signal to enable RF amplifier (Closed contact = Active)
- External “Trigger” input, 3v3 LV-TTL compatible
- External “Clock” input, 3v3 LV-TTL compatible

Additional features are available under software control.

Please refer to the Isomet Software Development Kit available on-line.

A summary of the driver specification is shown in the following table:

<u>Model</u>	<u>Use with</u>	<u>Output Frequency</u>	<u>Phase Shifted Outputs</u>	<u>Output Power per Channel</u>
RFA1170-4 + iMS4-L	LS700-1011	50 - 90MHz	Yes	> 80.0 Watt

Figure 2 shows a block diagram of the Driver.

The iMS4-L comprises two PCB's

Lower PCB features a four channel DDS and high speed FPGA with memory function.

Upper PCB is the main I/O interface and includes the USB II connection to the host

The -Enable signal is common to all four outputs. A closed contact between signal and ground will enable the RF power amplifier. No external pull-up is required and if a voltage is applied to this pin it must not exceed 3v3

The design includes thermal interlock protection which is also common to all four outputs

Each channel features a class A/B power stage to generate the final output level of up to 90W per output.

Water cooling is required. The heatsink temperature must not exceed 70°C.

- **SERIOUS DAMAGE TO THE AMPLIFIER MAY RESULT IF THE TEMPERATURE EXCEEDS 70°C.**
- **SERIOUS DAMAGE TO THE AMPLIFIER MAY ALSO RESULT IF THE RF OUTPUT CONNECTOR IS OPERATED OPEN-CIRCUITED OR SHORT-CIRCUITED.**
- **SERIOUS DAMAGE TO THE AMPLIFIER WILL RESULT IF THE (FLOATING) INTERLOCK INPUT SIGNALS ARE CONNECTED TO CHASSIS GROUND OR 0V**

A low impedance d-c power supply is required. The operating voltage is +24V at a current drain of approximately 32A. The external power supply should be capable of > 40A, with $\pm 2\%$ regulation and <200mV ripple voltage for best results.

Figure 1 shows the connections.

3. INSTALLATION AND ADJUSTMENT

- 3.1 For continuous or duty cycled operation above >2%, always connect cooling water. Flow rate greater than 2 litres / minute. Temperature < 20 deg.C (Factory fitted water connections suit 8mm OD plastic tubing).
- 3.2 Connect +24V DC to the screw terminals of the filtered DC connector. DO NOT APPLY POWER. The DC supply should be capable of 40A
- 3.2 Connect the (4) RF output TNC jacks to the (4) RF inputs of the acousto-optic deflector (or a 50Ω RF high power load). The connection order depends on the AO Bragg orientation (see Figure 4) and will be either 1→1, 2→2, 3→3, 4→4 or 1→4, 2→3, 3→2, 4→1. The deflector will not be damaged if the order is incorrect but the efficiency will be non-uniform. The amplifier outputs must be terminated.

The cable lengths from the amplifier to the RF connections of the deflector must be equal.

- 3.4 Connect the Interlock of the acousto-optic deflector (7-way circular connector) to the 7-way connector J9 of the RFA1170/4. A suitable cable is supplied.

The interlock signal triggers a fault condition if the temperature of the modulator or internal driver temperature exceeds 30°C. This will disable the RF outputs.

There are two LED indicators

- 1: The bulkhead LED (above RF output J2) is bi-colour.
- RED indicates 24Vdc is ON but the thermal interlocks and/or -ENABLE signal are inactive.
 - Yellow indicates interlocks are OK and the -ENABLE signal is active. RF will be output as soon as the iMS4-L is programmed and initiated.

- 2: LED stack on the iMS4-Interface PCB

A GREEN (or RED) LED will beat at 1Hz indicating that the interface control circuitry has initialized correctly

DO NOT connect any of the interlock signal wires to chassis ground or 0V.

3.5 Connect the USB to the host PC

3.6 Connect a voltage free contact to the -Enable SMA input.

3.7 Ensure the cooling water is on.

3.8 Apply + 24V DC to the amplifier

(The external trigger and clock inputs are not required for basic operation, depending on the desired operating mode).

3.9 Adjustment of the RF output power is best done with amplifier connected to the acousto-optic modulator.

The optimum RF power level required for the modulator to produce maximum first order intensity will be different at various laser wavelengths. Applying RF power in excess of this optimum level will cause a decrease in first order intensity (a false indication of insufficient RF power) and makes accurate Bragg alignment difficult. It is therefore recommended that initial alignment be performed at a low RF power level.

3.10 RF power is adjusted under software control

Please refer to the iMS SDK available at <http://www.isomet.com/software.html>

3.11 Set the power to a mid-level e.g.

<u>Class</u>	<u>Method description</u>	<u>Setting</u>
	UpdateDDSPowerLevel	80%
	UpdateRFAmplitude Wiper	40%

3.12 Program the DDS for a constant signal; Freq=70MHz, Ampl=100%, Phase=0 degree.
This will operate the AO device at its mid-scan position

3.13 Align the deflector head to insure that the incident light beam is centred in the active aperture of the deflector.

Observe the diffracted first-order output from the acousto-optic modulator and the undeflected zeroth order beam. Adjust the Bragg angle (rotate the deflector) to maximise first order beam intensity.

- 3.14 After Bragg angle has been optimized, slowly increase the RF power until maximum first order intensity is obtained. Record this intensity value (I_{SAT}).

Typical values:

<u>Class Method description</u>	<u>Setting</u>
UpdateDDSPowerLevel	80%
UpdateRFAmplitude Wiper	60%

- 3.15 To equalise deflection efficiency across the extremes of the scan, alternate between the minimum and maximum desired frequencies (e.g. 50MHz and 90MHz input resp') and adjust the PHASE and AMPL values to give the same efficiency at both positions. Fine tuning of the incident Bragg angle and RF power may be necessary for optimum results.

- 3.15 The amplifier is now ready for use.

Please contact Isomet for further guidance and example programs

-Enable Response

The -ENABLE (active LOW) should be applied 2msec prior to the required active RF output.
 The -Enable may remain LOW continuously. The RF amplifiers are design to be biased at 100% duty factor.

T_DLY = 1.8msec

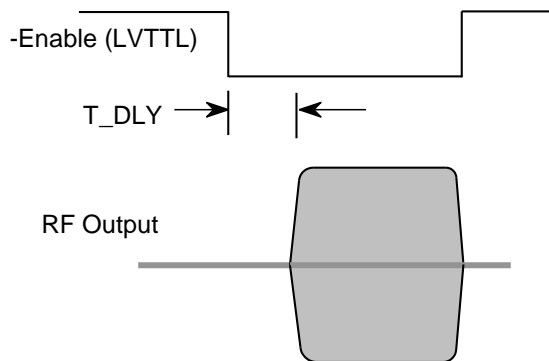

Pulsed Response

All versions of the RA1170-4 are designed for fast pulse operation up to CW operation
 Typical output RF waveform is shown below

45W / 70MHz pulsed output
 10%-90% rise / fall time = < 10nsec

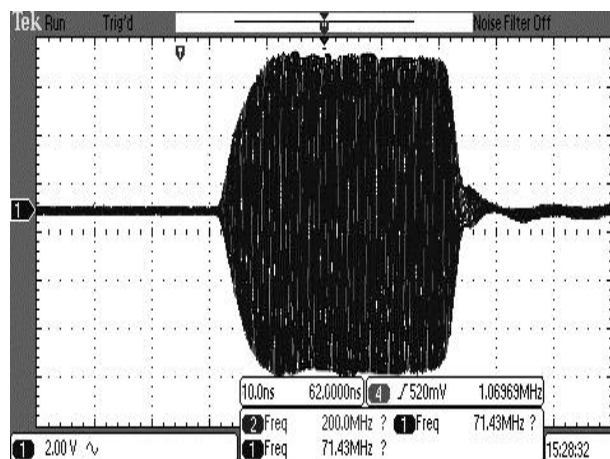

4. MAINTENANCE

4.1 AO Device - Cleaning

It is of utmost importance that the optical apertures of the deflector optical head be kept clean and free of contamination. When the device is not in use, the apertures may be protected by a covering of masking tape. When in use, frequently clean the apertures with a pressurized jet of filtered, dry air.

It will probably be necessary in time to wipe the coated window surfaces of atmospherically deposited films. Although the coatings are hard and durable, care must be taken to avoid gouging of the surface and residue of the cleaning solution. It is suggested that the coatings be wiped with a soft ball of brushed (short fibres removed) cotton, slightly moistened with clean alcohol. Before the alcohol has had time to dry on the surface, wipe again with dry cotton in a smooth, continuous stroke. Examine the surface for residue and, if necessary, repeat the cleaning.

4.2 Troubleshooting

No troubleshooting procedures are proposed other than a check of alignment and operating procedure. If difficulties arise, take note of the symptoms and contact the manufacturer.

4.3 Repairs

In the event of deflector malfunction, discontinue operation and immediately contact the manufacturer or his representative. Due to the high sensitive of tuning procedures and the possible damage which may result, no user repairs are allowed. Evidence that an attempt has been made to open the optical head will void the manufacturer's warranty.

Schematic of Acousto-optic scanner and drive electronics.

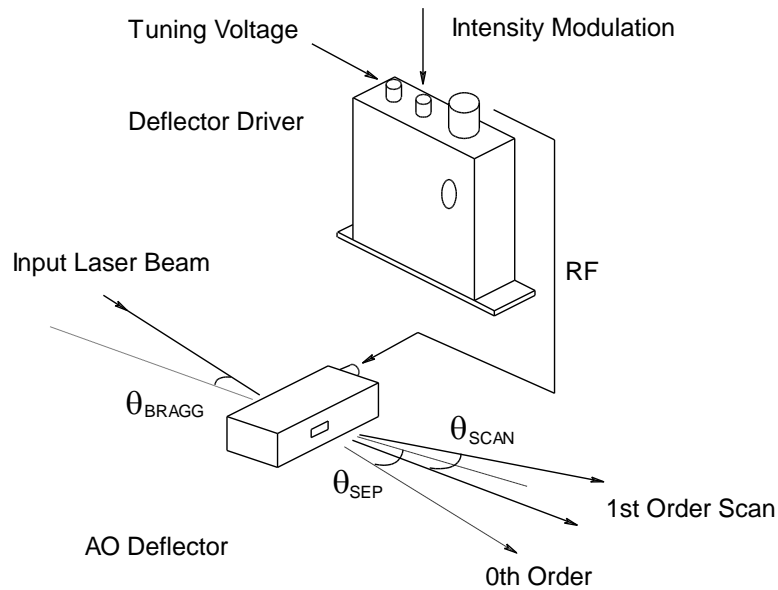

The input Bragg angle, relative to a normal to the optical surface and in the plane of deflection is:

$$\theta_{\text{Bragg}} = \frac{\lambda \cdot f_c}{2 \cdot v}$$

The separation angle between the zeroth order and mid scan point of the first order is:

$$\theta_{\text{sep}} = \frac{\lambda \cdot f_c}{v}$$

The first order scan angle is:

$$\theta_{\text{scan}} = \frac{\lambda \cdot \delta f}{v}$$

Modulation rate (Gaussian profile) is:

$$T_r = 0.65 \cdot d/v$$

Scanning Resolution is:

$$N = \delta f \cdot d/v$$

where :

- λ = wavelength
- δf = scan frequency bandwidth
- f_c = centre frequency
- v = acoustic velocity of interaction material (5.5mm/us for Ge)
- d = beam waist along acoustic axis

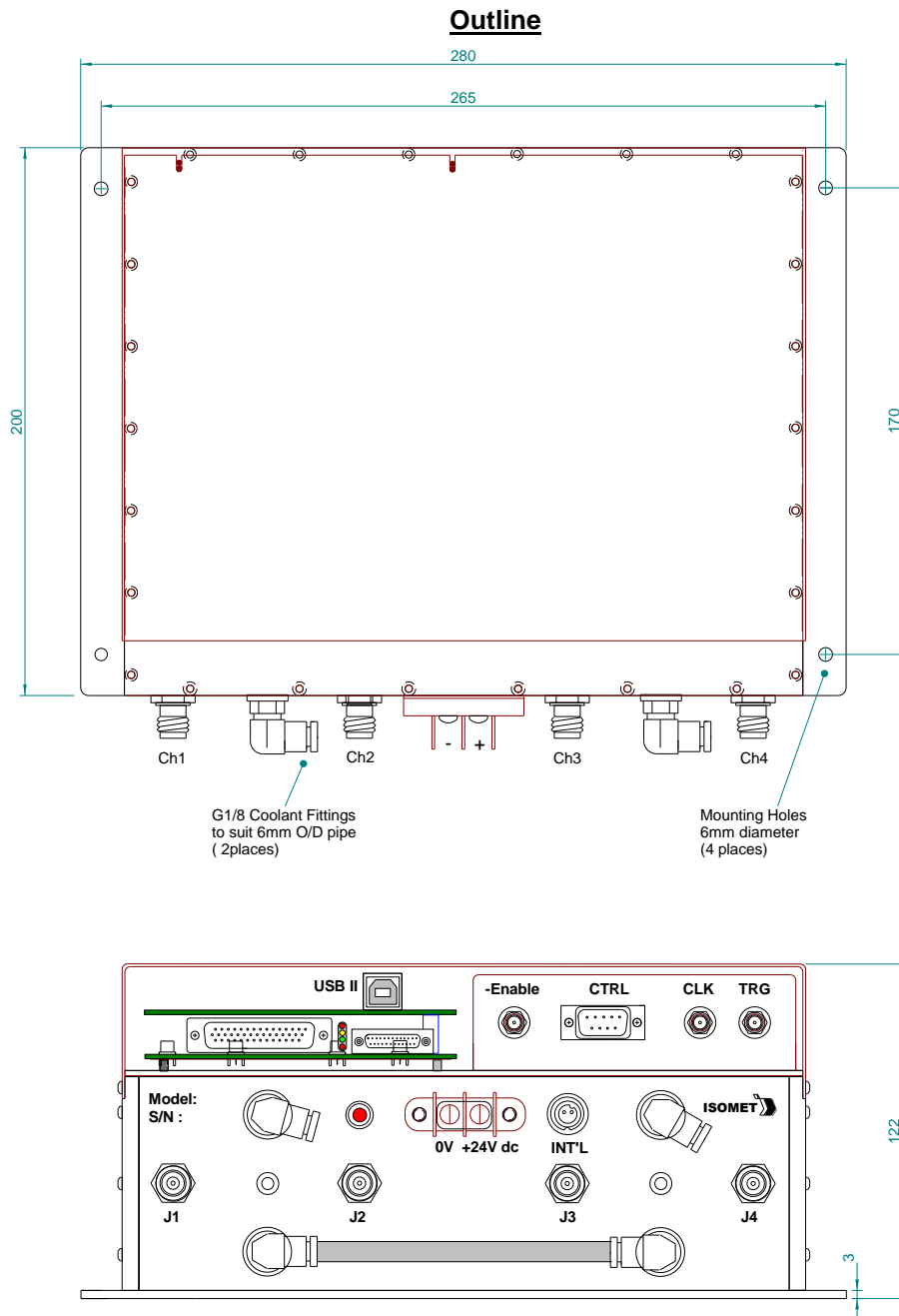

Connector Summary

- J1:** TNC, RF Output Ch1
- J2:** TNC, RF Output Ch2
- J3:** TNC, RF Output Ch3
- J4:** TNC, RF Output Ch4
- INT:** 7-way Circular Panel Plug, Binder 712 (AOD Temp and isolated Interlock Input)

- USB II:** Host PC USB connection
- CTRL:** Reserved for future use
- CLK:** External data clock input
- TRG:** External trigger input
- Enable:** Connect signal to return to enable

Figure 1: Driver Installation

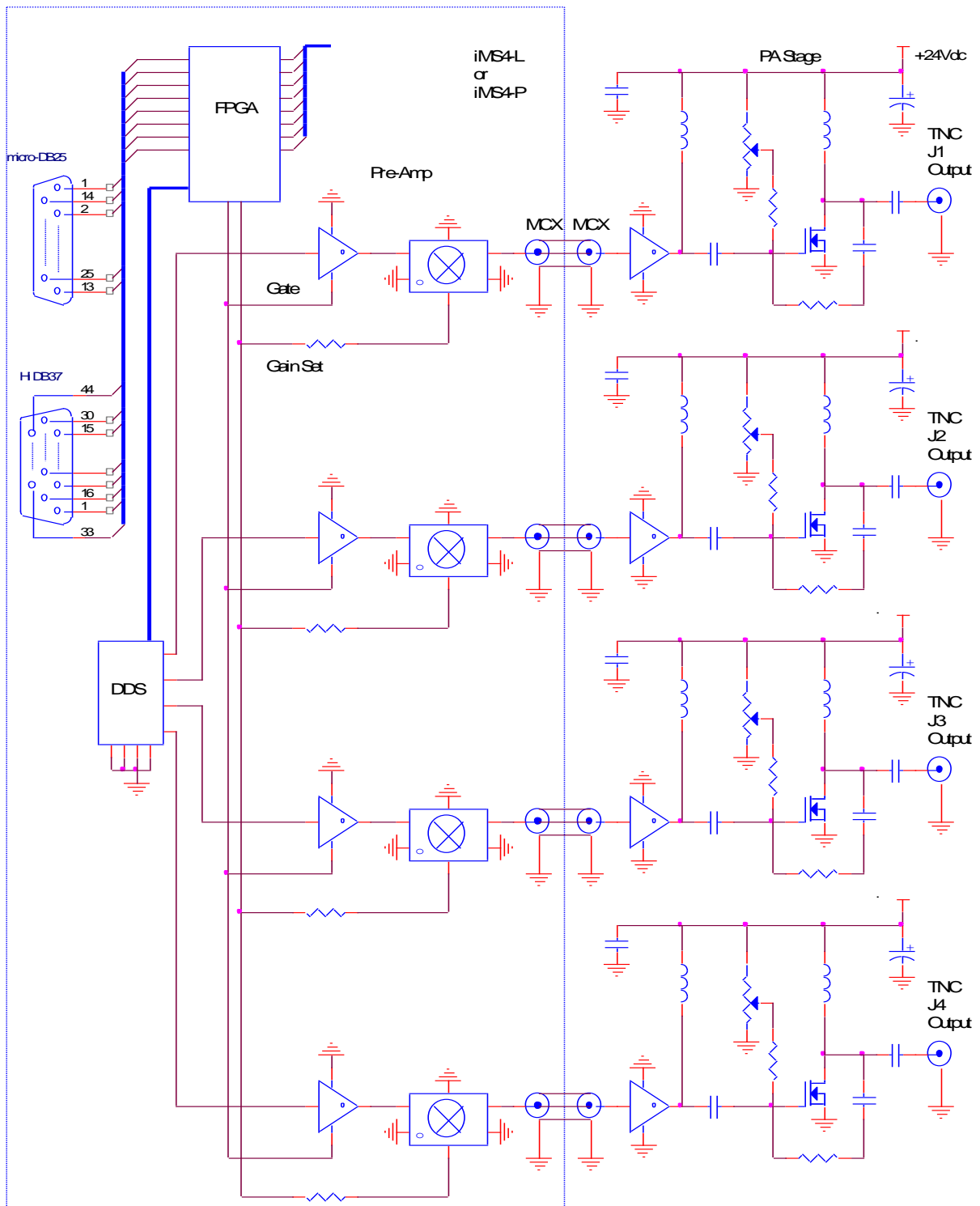

Figure 2: Driver Block Diagram

Signal	Connector	Spec
-Enable	SMA	Internal pull up to 3v3 Voltage free contact recommended Open = Off, Closed =ON
CTRL	9-way D-type	Reserved for future designs
CLK	SMA	LVTTL, 3v3 max
TRG	SMA	LVTTL, 3v3 max
USB	B-type	II
INT	7-way Binder	I2C (cable supplied)
Vdc	Screw terminal	24Vdc , 40A

LED indicators, 2 off:

1: The bulkhead dual colour LED fitted above RF output J2

RED indicates:

24Vdc is ON, but one or more of the following conditions exist:

Interlock failure (over temp)

-ENABLE signal inactive (open circuit)

RF_GATE not enabled in S/W

YELLOW indicates amplifier enabled and RF outputs live

2: LED stack on the iMS4-L interface PCB

GREEN (or RED) LED will beat at 1Hz indicating that the interface control circuitry has initialized correctly

Figure 3: Signal listing

Connection options for Beam Steered AO Deflectors

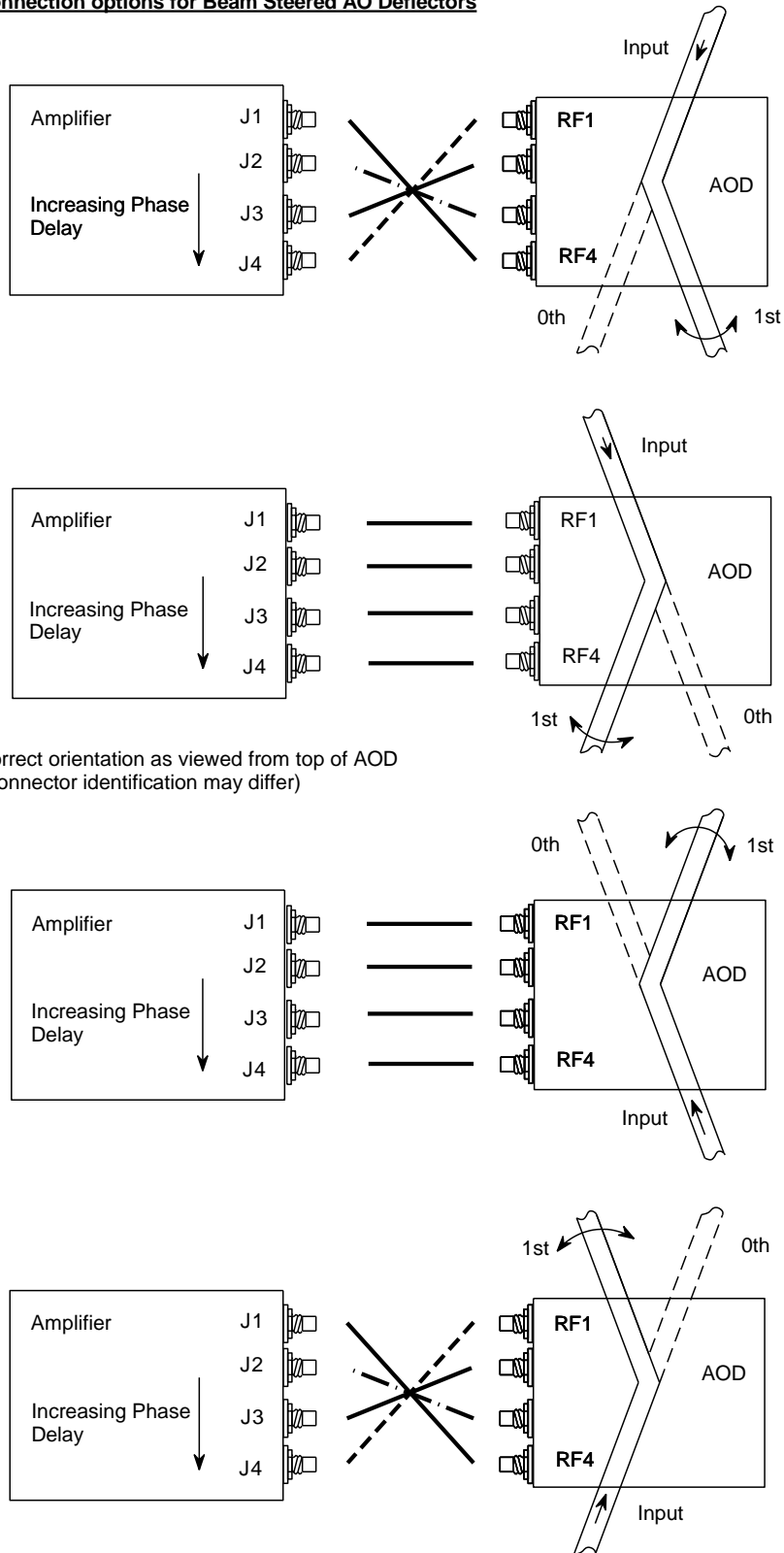

Figure 4: Connection Orientation. (Assumes the iMS4-L is programmed accordingly)